

AUCMA

MetaFridge[®] CFD-50

User's Manual



Please read the manual carefully before use

Keep the manual in a safe place for future reference

All material that is labeled with  may affect either product safety or user's safety and should be handled with caution.

Contents

1	Product Description	3
2	CFD-50 Components	4
3	Transport and Handling Instructions	6
4	Installation	7
4.1	Preparation	7
4.2	Positioning the CFD-50	7
4.3	Filling Instructions	9
4.4	Cooldown	11
5	Use of the CFD-50	12
5.1	Vaccine Chamber	12
5.2	Temperature Display and Status LED	12
5.3	30 DTR (Daily Temperature Record) Display	13
5.4	Alarms	16
5.5	USB Download and 30 DTR reports	18
5.6	System Battery	19
5.7	Remote Temperature Monitoring System (optional)	19
6	Maintenance	19
6.1	Daily maintenance tasks	19
6.2	Monthly maintenance tasks	19
6.3	Annual maintenance tasks	19
6.4	Cautions during maintenance:	19
7	Safety Precautions	20
8	Troubleshooting	21
9	CFD-50 Specification	24
10	CFD-50 Disposal and Recycling Guidelines	24
11	Warranty	24

1 Product Description

The MetaFridge CFD-50 is a WHO PQS certified vaccine refrigerator that maintains a temperature between 2-8 °C with multi-day holdover during extended power outages. It includes integrated power protection, a display showing 30 days of temperature and alarm history, onboard logging of temperature and diagnostic data, and it supports remote monitoring of performance data.

CFD-50 standard features:

- 50-liter vaccine storage chamber volume
- Front-opening for easy user access to vaccines
- Integrated power protection system defending against voltage spikes and brown-outs
- Integrated voltage stabilization to utilize a wide range of input voltages (110 – 230 VAC)
- Normal operation in a minimal mains grid access environment (maintains temperatures with as little as 3 hours of power a day on average)
- ColdSafe™ cooling technology, providing 120 hours of holdover at constant ambient temperature of 43 °C (192 hours at constant ambient temperature of 25 °C)
- Integrated 30-day temperature record (DTR) display and downloadable temperature history
- Integrated plastic base prevents corrosion from damp floor
- Remote temperature monitoring feature is available upon request

2 CFD-50 Components

Components of the CFD-50 are labeled below. Refer to the maintenance manual for more information and how to order spare parts.

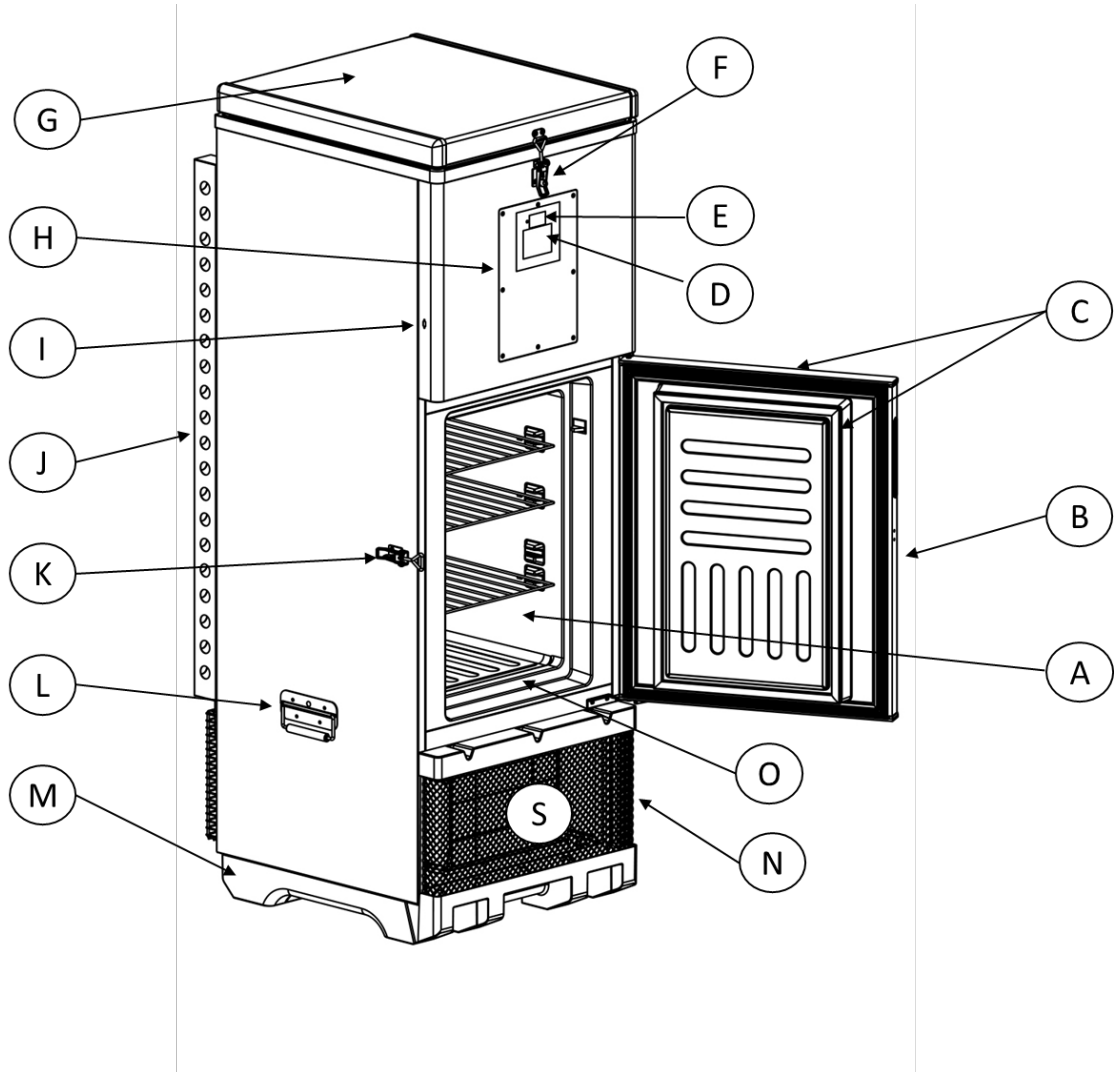

- | | | |
|---------------------------|------------------------------|--------------------------------|
| Ⓐ Vaccine chamber | Ⓑ Vaccine chamber door | Ⓒ Vaccine chamber door gaskets |
| Ⓓ 30-DTR display | Ⓔ Temperature display | Ⓕ Water tank lid latch |
| Ⓖ Water tank lid | Ⓗ Electronics enclosure | Ⓖ USB port |
| Ⓙ Condenser guards | Ⓚ Vaccine chamber door latch | Ⓛ Lifting handles |
| Ⓜ Integrated plastic base | Ⓝ Front ventilation cover | Ⓞ Condensation drain channel |

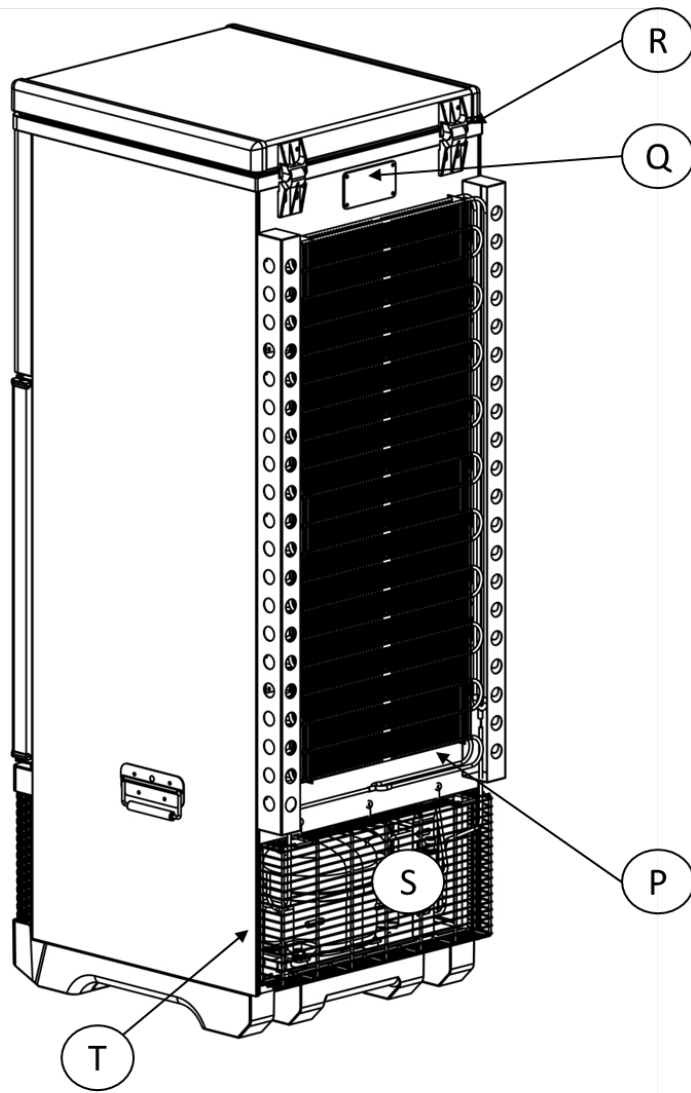

Ⓟ External condensers

Ⓠ Thermal safety shut-off
(mechanical thermostat)

Ⓡ Water tank lid hinge

Ⓢ Compressor compartment

Ⓣ Back ventilation cover

(contains compressor, fan, power enclosure and power board, transformer, drain pan)

3 Transport and Handling Instructions

 Heavy object warning. To avoid injury, use lifting aids and proper lifting techniques when moving the CFD-50

- a. **Leave the CFD-50 in its protective packaging** as long as possible to protect from damage
 - Cutouts in the cardboard allow access to the manufacturer's label for inspection and to the handles for lifting without removing the packaging.
- b. **Transport the CFD-50 vertically when possible:**
 - If transport on the side is necessary, pay attention to "This side up" markings on the packaging and make sure package is in the correct orientation to prevent damage.
- c. **Keep door and top lid closed and latched** when moving the CFD-50
- d. If the CFD-50 needs to be moved after initial installation, **remove the water from the water tank using a siphon hose before moving.**
- e. **When using the handles for lifting**, keep one hand towards the top of the unit to prevent tipping.
- f. **Avoid any excessive force** to prevent damage to the CFD-50.
 - Avoid any excessive force especially towards the door and lid to prevent damage.
 - Do not lift the CFD-50 from the doors, grates, or condenser guards.

4 Installation

4.1 Preparation

- a. Read the instruction manual carefully.
- b. Remove all packaging materials, including foam base and tape.
 - Discard plastic wrappers and bags safely, to avoid suffocation of children.
- c. Inventory accessories and installation tools to make sure there are no missing parts. Each CFD-50 should include the following parts shipped inside the vaccine chamber:
 - 3 shelves
 - 2 plastic vaccine trays (additional trays can be ordered)
 - 1 funnel for filling the water tank to commission the CFD-50
 - User manual and maintenance manual
 - 2 sets of lock and key, for the water tank and vaccine chamber

If any parts are missing, please contact the manufacturer or service provider.

4.2 Positioning the CFD-50

- a. Place the CFD-50 on a flat and solid ground and **ensure the unit is level**.
- b. **No pallet is required:** CFD-50 has an integrated plastic base.
- c. Position the CFD-50 near an accessible electrical outlet; the power cord length is 2 meters.
- d. Position the CFD-50 **away from direct sunlight and any source of heat** (e.g. gas stove, fireplace, etc.).
- e. CFD-50 must not be placed in or around flammable or corrosive gases that could cause an explosion or electric shock.
- f. In order to prevent rust or electrical leakage, the CFD-50 should not be placed in a high humidity environment or in a location where it could be splashed with water or rain.

- g. Position the CFD-50 in a **well ventilated area** and **make sure there is a minimum of 10 cm of empty space around the sides and back of the unit. The door latch must be accessible and the door must be able to open freely to at least 90°.**
- h. Allow a minimum of 60 cm clearance above the CFD-50 for accessing the water tank lid.

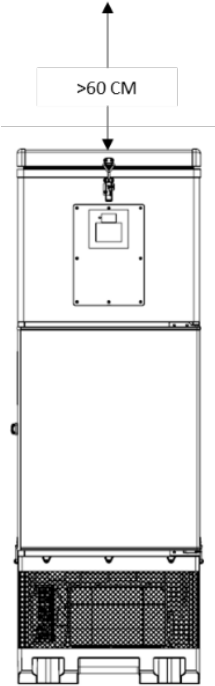
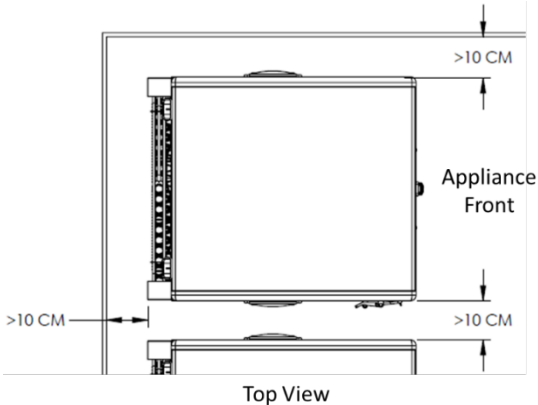



4.3 Filling Instructions

 CFD-50 must be properly filled with clean drinking water before operation and use. During the filling process, use care and common sense and follow all local safety precautions

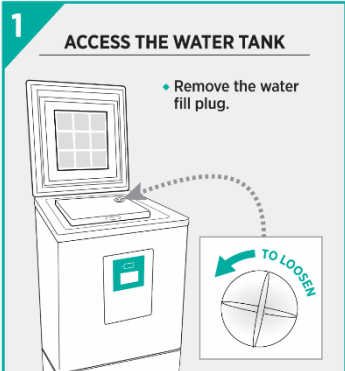
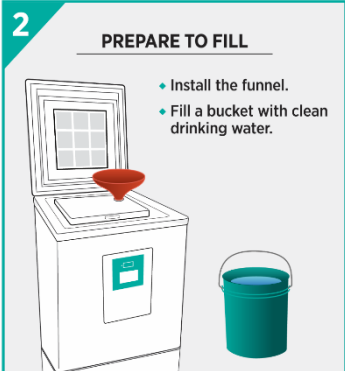
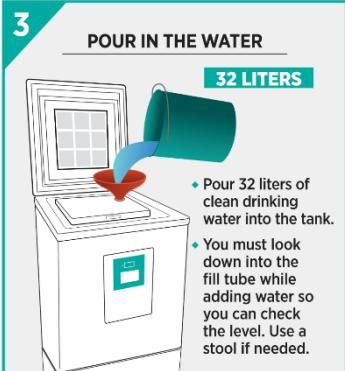
Filling instructions can also be found on the inside of the water tank lid.

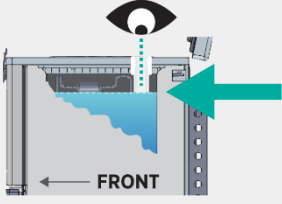
<p>1 ACCESS THE WATER TANK</p> <ul style="list-style-type: none">Remove the water fill plug. 	<p>Step 1: Unlatch the water tank latch and fully open the water tank lid. Turn the fill plug counterclockwise to loosen and remove the cap. Keep the plug on top of the water tank while filling so it does not get lost.</p>
<p>2 PREPARE TO FILL</p> <ul style="list-style-type: none">Install the funnel.Fill a bucket with clean drinking water. 	<p>Step 2: A funnel is shipped inside of each CFD-50. Install the funnel securely in the fill hole. Fill a bucket with clean drinking water. If there is no local source of clean drinking water, use bottled water.</p>
<p>3 POUR IN THE WATER</p> <p>32 LITERS</p> <ul style="list-style-type: none">Pour 32 liters of clean drinking water into the tank.You must look down into the fill tube while adding water so you can check the level. Use a stool if needed. 	<p>Step 3: Pour 32 L of water into the water tank through the funnel. If needed, use a stool to properly reach the funnel and be able to look down into the fill tube to check the water level.</p>

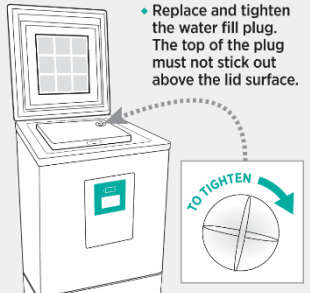
<p>4 CHECK THE WATER LEVEL</p> <ul style="list-style-type: none"> ♦ Fill the tank until the water is just touching the bottom of the fill tube. ♦ DO NOT INSERT SHARP OBJECTS INTO THE FILL TUBE. 	<p>Step 4: While filling, stop periodically to check the water level by looking down into the tube with a light. The water should just reach the bottom of the fill tube.</p> <p>Do not insert sharp objects into the tube or you may damage the refrigerator evaporator.</p>
<p>5 REMOVING WATER</p> <ul style="list-style-type: none"> ♦ To remove excess water, or to empty the tank, use a siphon hose. 	<p>Step 5: If you accidentally overfill the water tank, remove excess water using a piece of tubing as a siphon. Adjust the water level by adding/removing water until the water level is at the bottom of the fill tube.</p> <p>Too little water will reduce holdover time; too much water may damage the unit.</p>
<p>6 SEAL THE WATER TANK</p> <ul style="list-style-type: none"> ♦ Replace and tighten the water fill plug. The top of the plug must not stick out above the lid surface. 	<p>Step 6: When water is at the correct level, replace the fill plug and tighten until the plug is entirely within the lid and will not interfere when the top lid is closed.</p>

⚠ Do not overfill the CFD-50 (Figure G).
Remove excess water if overfilling occurs (Figure H).

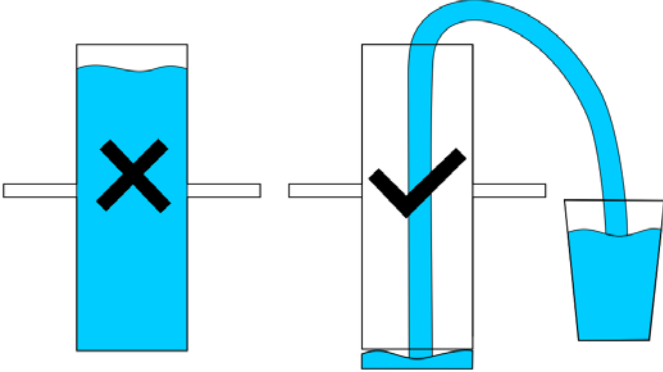





Figure G Figure H

4.4 Startup and Cooldown

 Ensure that the water tank has been filled to the correct level before plugging in the CFD-50

1. Use a #2 Philips screwdriver to open the front electronics enclosure.
2. Connect the main battery. Once powered on, the temperature display will show the temperature of the vaccine chamber.
3. Plug the CFD-50's power cord into a dedicated outlet. If mains power is available, the compressor will start after a delay of 5 minutes.
4. If telemetry module is installed, also connect battery on the telemetry module.
5. Open the vaccine cabinet door to check if interior light is on and close the door. To enable or disable interior light, refer to the maintenance manual.
6. If mains power is available, wait until compressor has started (indicated by green LED next to the temperature display) and verify that sides of the CFD-50 become warm to the touch after a few minutes of running, before replacing the electronics enclosure lid.
 - a. If mains power is not available, close the electronics enclosure and follow up the next day in person or by phone to verify the installation.
7. If compressor run LED does not come on or sides of the unit do not become warm after compressor has run for several minutes, consult troubleshooting section of the maintenance manual.
8. Do not use the CFD-50 until the display indicates that the vaccine chamber temperature is below 8 °C and the 30 DTR indicates at least 2 days of remaining holdover, which typically takes <6 hours with continuous power availability.

 In the case of intermittent power (≤ 4 hours of power each day) and high ambient temperature environment, the CFD-50 may require 2 days after initial installation to reach full holdover capability.

 During the initial cooldown, do not use the CFD-50 until the display indicates that the vaccine chamber temperature is below 8 °C and the 30 DTR display indicates at least 2 days of remaining holdover.

5 Use of the CFD-50

- Check the temperature display daily and make sure the chamber temperature is between 2-8 °C before using.
- Do not overfill the vaccine chamber. Leave gaps between vials and boxes to enable cold air circulation within the chamber. Use trays to organize vaccines and keep boxes from touching the walls or sitting directly on the floor of the vaccine chamber.
- Keep vaccine chamber door tightly closed and latched when not in use to maintain the storage temperature inside
- There is no user-adjustable thermostat or sensors in the CFD-50.
- Designate a person to inspect and record the daily operation to ensure the safe use of the CFD-50.
- Only approved vaccines or medical supplies should be stored in the refrigerator. Do not store any foods, beverages, or flammable, explosive, volatile items (such as alcohol or gasoline) or other dangerous items in CFD-50.

5.1 Vaccine Chamber

All parts of the vaccine chamber are controlled between 2-8 °C and are suitable for vaccine storage.

Loose vials should be stored in the provided trays on shelves inside the vaccine chamber. Secondary packaging may be placed directly on shelves or in trays. Do not place secondary packaging directly on the bottom of the vaccine chamber to avoid contact with any excess condensation. Also avoid leaving secondary packaging in direct contact with the chamber walls.

When mains power is available, a LED light will illuminate the vaccine chamber when the door is open. If desired, the light can be disabled so it does not turn on when the door is opened – refer to maintenance manual for details.

In humid environments condensation may collect on the sides and back of the vaccine chamber, and run down the walls into the drip channel surrounding the bottom of the chamber. Any accumulated condensation will flow to the back of the chamber and out through the drain hole.

5.2 Temperature Display and Status LED

The top display shows the actual temperature in the CFD-50 vaccine chamber. The temperature sensor and thermostat are factory calibrated and set. The user does not need to adjust any temperature settings.

The red LED blinks when an alarm is occurring.

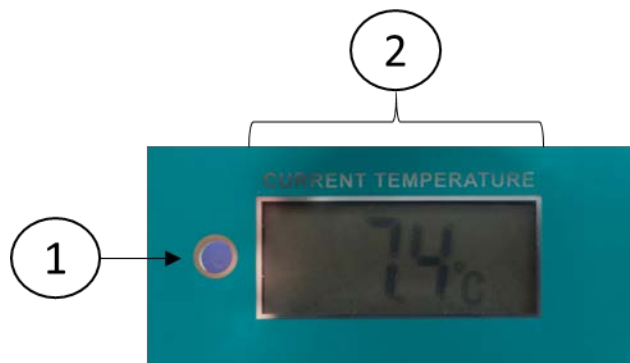

Current temperature and status

1. Status LED	The LED to the left of the display will be: <ul style="list-style-type: none"> • green while the compressor is running, or • blinking red during alarms
2. Current vaccine chamber temperature	Temperature display showing the coldest point in the vaccine chamber

The temperature display has an independent power source and will continue to display the temperature for 3 days without mains power or a system battery. If power is not restored in that time, the display will go blank until mains power is restored or a charged system battery is installed.

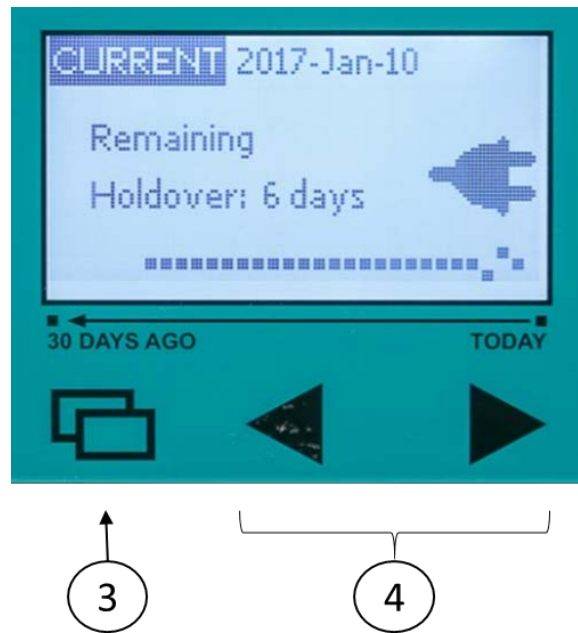

5.3 30 DTR (Daily Temperature Record) Display

The larger bottom display shows the temperature and alarm history over the past 30 days, as well as information about currently remaining holdover, current power availability, and ongoing alarms.





30 DTR display and navigation buttons

Navigation buttons

3. Menu button 	Tap the Menu button to move between CURRENT, HISTORY, and ALARM screens.
4. Back and Forward buttons 	Use the back and forward buttons to move backwards and forwards through the HISTORY screens to view temperature and alarm statistics from the past 30 days.





Current Screen: This is the default screen that shows status of the unit during regular operation.

5. Remaining holdover	Calculated remaining holdover time without power. This is an estimate only and not a guarantee of remaining holdover.
6. CURRENT screen	The CURRENT screen is the default screen that displays the CFD-50's status overview.
7. Date	The current date (default time zone is UTC).
8. Replace battery icon	 <p>The CFD-50's monitoring system is powered by a rechargeable battery. This icon will appear if the battery is not plugged in or if it has degraded over time and needs to be replaced.</p>
9. Plug icon button	 <p>The power icon indicates whether mains power in the CFD-50's usable range (82 – 290 V) is currently available. A slash through the plug indicates that power is off or outside of CFD-50's input range.</p>
10. Alarm history indicators	 <p>Dots indicate vaccine chamber temperature range during each of the past 30 days. The current day is the rightmost dot, and the leftmost dot is 30 days ago. A raised dot represents a high temperature excursion on that day, a low dot represents a low temperature excursion, a neutral dot represents no temperature excursion. If no data is available for a day, no dot will be shown.</p>

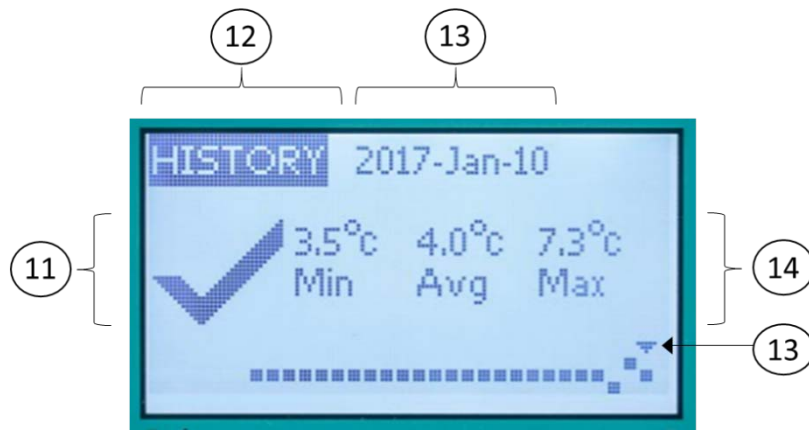
To view temperature and alarm history, from the CURRENT screen press the MENU button to go to the HISTORY screen



History Screen: Shows temperature and alarm statistics from each of the past 30 days.

11. Check/Alarm icon		The check/OK icon indicates that no temperature excursions occurred on the day being viewed.
		The alarm/X icon indicates that one or more temperature excursions occurred on the day being viewed. Press the back button to view alarm details.
12. HISTORY	HISTORY screens display summary information for each of the past 30 days	
13. Date	The date currently being viewed. An arrow towards the bottom of the screen indicates which of the past 30 days is being viewed.	
14. Temperature history	For each day, the minimum, average, and maximum recorded temperatures are shown.	

To view details for each temperature excursion, use the backwards and forwards buttons to navigate to the day when the excursion occurred. An extra screen will appear for each excursion that occurred on that day. An excursion that spans multiple days will trigger an alarm for each day.

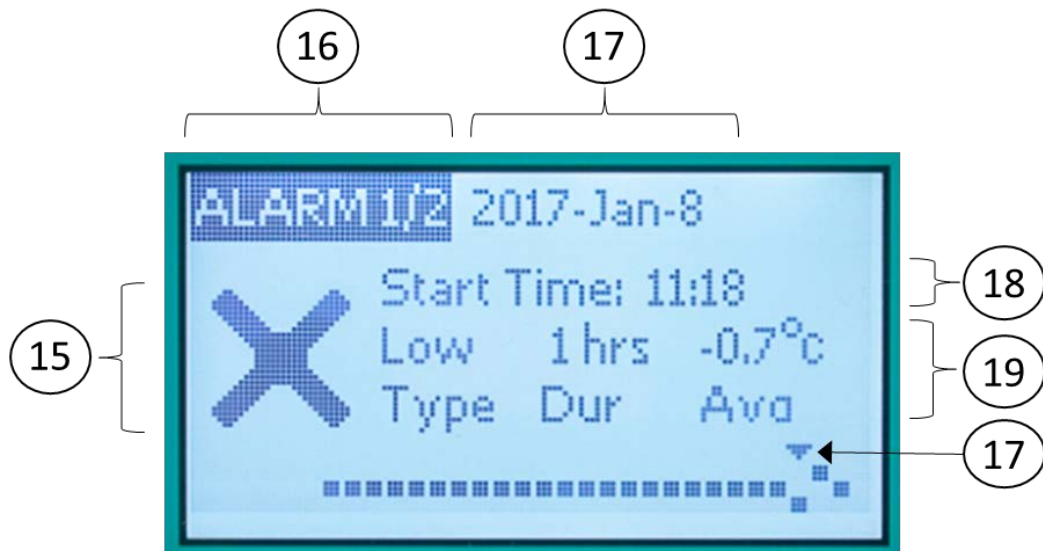

Alarm History Screen: Shows information about each alarm that occurred over the past 30 days.

15. Check/Alarm icon	The alarm/X icon indicates that an alarm is being viewed.
16. ALARM screen / alarm number	ALARM screens show detail on each temperature alarm. Numbers indicate how many excursions occurred on the day being viewed, and which alarm is currently being viewed. "Alarm 1/2" indicates that two alarms occurred on this

	day and details for the first alarm are currently shown. Press the back and forward buttons to move between alarms.
17. Date	The date currently being viewed. An arrow towards the bottom of the screen indicates which of the past 30 days is being viewed.
18. Start time	The time (in 24-hour format, default time zone is UTC) indicates when the temperature excursion began. Note that the alarm time begins after the temperature excursion time threshold is exceeded – if the high temperature excursion threshold is 10 hours above 8 °C, the alarm will begin 10 hours after the temperature first exceeds 8 °C. Separate alarms occur when an alarm spans multiple days – an alarm that begins at 00:00 is likely a continuation of the same excursion as the previous day.
19. Temperature history	For each alarm, the type of excursion, duration of the excursion (excluding time elapsed while triggering the alarm), and average temperature during the excursion.

After 1 minute of inactivity the display will dim and prepare to go to sleep. Pressing any button during this time will wake up the display without changing the visible screen. After an additional minute of inactivity, the display will turn off, and any button press will bring up the CURRENT screen, or if there is an ongoing alarm, the ACTIVE ALARM screen.

Note: The backlight will only operate when mains power is available and battery is fully charged. During extended power outages the display will still function without backlight.

5.4 Alarms

CFD-50 has five kinds of alarms:

- 1) High temperature excursion (defined by WHO PQS): 10 hours above 8 °C
- 2) Low temperature excursion (defined by WHO PQS): 1 hour below -0.5 °C
- 3) Close door: Door open for more than 20 minutes
- 4) Low holdover: 2 days of holdover remaining unless power is restored
- 5) No holdover remaining: All ice lining has melted and vaccine chamber is beginning to rise

After an alarm condition is triggered the Active Alarm screen will show, the red LED will blink (on for 1 s, off for 4 s) and the audible buzzer will sound (on for 1 s, off for 4 s). Pressing any button will silence the audible alarm and allow the ACTIVE ALARM screen to go to sleep, but the red LED will continue flashing until the alarm condition has ended.

The Active Alarm screen shows the alarm type and associated information.

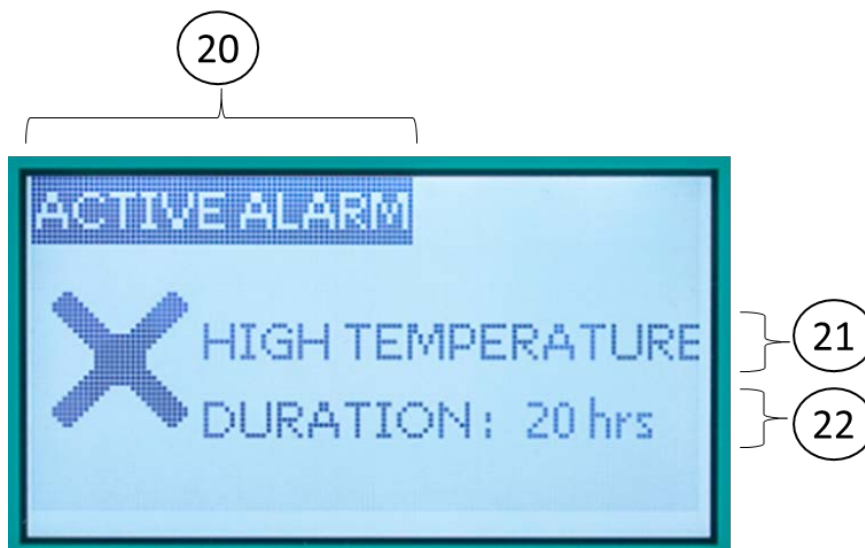

Active Alarm Screen: Shows information about a currently ongoing alarm.

20. ACTIVE ALARM screen	ACTIVE ALARM indicates that an alarm is currently ongoing. This screen will continue showing until the alarm condition has ended. Touching any button during an active alarm will silence the audible alarm and allow the display to go to sleep.
21. Alarm type	Text indicates which type of alarm is occurring.
22. Alarm information	<p>For temperature excursions, the duration of the excursion is shown. See troubleshooting guide in Chapter 8 for potential causes of temperature excursions and suggested remedies.</p> <p>For door excursions, the duration of the excursion is shown. If additional time is needed for loading or unloading vaccines, the door timer can be reset by briefly closing the door, or the alarm can be silenced by touching any button of the 30 DTR display.</p> <p>For holdover alarms, “RESTORE POWER” is displayed.</p> <p>A low holdover alarm indicates that the estimated remaining holdover is less than 2 days and the user may need to take action to restore power or find backup cold storage for the vaccine payload.</p> <p>A no holdover alarm indicates that all of the CFD-50’s ice lining has melted and the vaccine chamber is warming up. Power should be immediately restored or vaccines should be removed to backup cold storage.</p>

Pressing the Menu button from the ACTIVE ALARM will show the CURRENT and HISTORY screens and allow normal navigation. After the display turns off due to inactivity, the first button touch will again bring up the active alarm screen.

Alarm Acknowledgement

The 30 DTR report shows the time that each temperature excursion begins, ends, and when the alarm was acknowledged. A button press that silences an alarm counts as an acknowledgement. If a high or low temperature excursion alarm occurs, and ends before a button is pressed to silence and acknowledge the alarm, the ALARM ENDED screen will show the user which alarms occurred in their absence. The user will be asked to touch any button to acknowledge. Door excursions and holdover alarms do not require acknowledgement after the alarm condition returns to normal. Even if multiple alarms have occurred without being acknowledged, only one ALARM ENDED screen will be shown. Full alarm history can still be viewed through the ALARM HISTORY screens.



Alarm Ended Screen: Displays information about the most recent un-acknowledged temperature alarm.

5.5 USB Download and 30 DTR reports

The CFD-50 appears as a USB mass storage device when connected to a computer through the USB port on the left side of the CFD-50 using a micro USB cable (provided in the technician kit).

In the top level directory of the storage drive are the latest 30 DTR reports in .csv and .pdf formats. Other folders hold documentation (such as this manual) and 30 DTR reports covering the entire time since the refrigerator was installed.

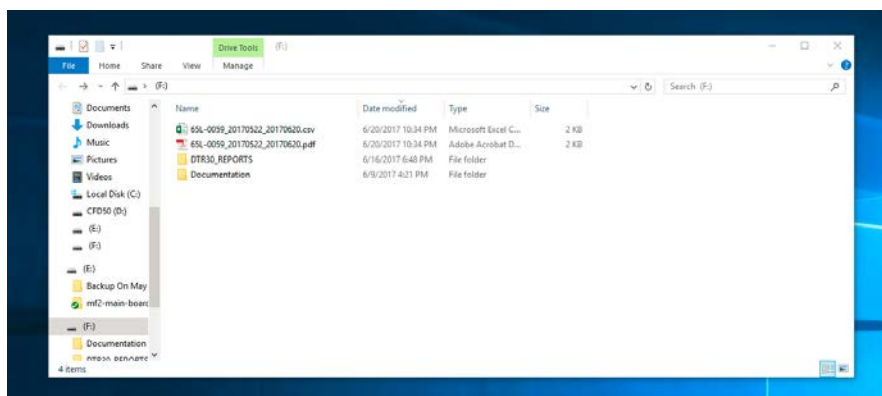

CFD-50 Mass storage device: contains .pdf and .csv versions of the most recent 30 DTR reports. User manuals and older 30 DTR reports are available in subfolders.

The 30 DTR reports are labeled with the last 7 digits of the unit's manufacturer's serial number (also on a label on the back of the unit) and the date range covered in the report.

5.6 System Battery

The 30 DTR and display are powered by a Li-ion battery installed in the electronics enclosure. A new battery will allow the system to continue to monitor and display temperatures for 1 week without mains power. During longer outages, the battery may drain completely and the 30 DTR display will no longer function until mains power is restored or the battery is replaced. Over time, the battery will degrade and lose capacity and will need to be replaced. Replacement batteries are available from Aucma or service providers; refer to maintenance manual for battery replacement instructions.

5.7 Remote Temperature Monitoring System (optional)

CFD-50 is compatible with approved third-party remote temperature monitoring systems that can be connected to the main electronics board at the factory or by a trained technician. If your CFD-50 comes with the remote monitoring option, refer to the third-party documentation. For more information, contact the manufacturer or service provider.

6 Maintenance

6.1 Daily maintenance tasks

- Confirm that the vaccine chamber is within acceptable temperature range (2°C to 8°C) and remaining holdover is at least 2 days. If temperatures are out of range or holdover is low, follow troubleshooting steps in Chapter 8.
- Ensure that door is fully closed and latched. Avoid unnecessary door openings.

6.2 Monthly maintenance tasks

- Wipe down any condensation inside the vaccine chamber
- Remove any surrounding objects around the CFD-50 that might obstruct airflow.
- Clean external condensers at the back of the CFD-50.
- Clean both front and back compressor ventilation covers.
- Clean vaccine chamber door inner and outer gaskets with a soft wet cloth to maintain flexibility and elasticity. Rub the door gasket with talcum powder to prolong its use. Check gaskets for any cracks or gaps that allow airflow through the door. Order spare parts and replace if necessary.

6.3 Annual maintenance tasks

- Inspect water level to ensure that water reaches the bottom of the fill tube; top off with clean drinking water if needed. It is normal for ice to be present in the bottom of the fill tube.

6.4 Cautions during maintenance:

- Wipe both inner and outer surfaces using a soft cloth. Do not use any brushes, acidic or alkali detergents.
- In order to avoid water leakage to electric component and damage to the exterior, do not pressure-wash or use

any hard scrub to clean the CFD-50.

- Before decommissioning or storing the CFD-50, unplug the unit, drain all water, clean the inside thoroughly, use a dry cloth to wipe the interior and leave the door and top lid open for 2 to 3 days until the inside is completely dry.

7 Safety Precautions

- a. Plug the CFD-50 into a standard electrical socket; appliance is rated for use with either 110-120 V or 220-240 V, 50 or 60 Hz.
- b. Use reliable grounding that is tied to the earth; not connected to any grid, heating pipe, gas pipe, etc..
- c. Hold the plug firmly and pull to disconnect power. Do NOT pull on the cord to disconnect power.
- d. For safety reasons, conduct any repair work by unplugging the unit before starting the work.
- e. Do not use wet cloth to wipe any electrical parts.
- f. Do not place or operate the CFD-50 near any inflammable, explosive, corrosive materials, any volatile gases, liquids, and any inflammable gases.
- g. Do not touch any electrical components (such as plugs, switches, etc.) with wet hands in order to avoid electric shock.
- h. Do not damage or break the power cord and power plug or use a plug with a loose cord, in order to prevent fire and electric shock. Replace any damaged power-supply cords or plugs immediately by qualified maintenance personnel.
- i. Do not place any water containers or heavy objects on the top of the CFD-50 to avoid any damage to the top, any injury due to falling objects, or any electric leakage or electric shock due to splashing water on any electric components.
- j. Do not climb onto or lean on the CFD-50, which may cause injury due to tilting or falling of unit.
- k. Do not touch the compressor when the CFD-50 is plugged in to avoid being burned or injured.
- l. Do not allow children to play in inside of the CFD-50, which may cause damage or injury.
- m. Remove the door when the CFD-50 is no longer in use so children cannot be trapped inside.

8 Troubleshooting

If CFD-50 does not work properly, please proceed as described in the troubleshooting guide below.

If the problem cannot be resolved, please contact the manufacturer or the service provider.

Symptom	Possible Cause	Remedy
Vaccine chamber temperature above 8 °C	Prolonged door opening or door ajar	Avoid prolonged door openings and make sure door is fully closed and latched after use. Vaccine chamber may take some time to cool down again after extended door openings.
	Warm objects placed in the vaccine chamber	Do not place food, beverages, or other non-medical items inside the refrigerator.
	Door gasket not sealing properly	Check gasket condition; adjust door or replace gasket if necessary.
	Improper air flow around condensing unit	Re-arrange to allow proper air circulation; relocate the refrigerator away from heat-generating equipment, direct sunlight, or direct path of air conditioning or heating ducts.
	Power cord unplugged	Plug in power cord.
	Insufficient mains power unavailable	Check facility wiring or contact electricity supplier.
	Improper voltage supplied to refrigerator	Correct supply voltage and ensure the power outlet voltage matches the CFD-50's voltage input requirements.
Vaccine chamber temperature is below 2°C	Ambient temperature is below 10 °C	Move the CFD-50 to a warmer location. Note that the CFD-50 is rated from 10 °C to 43 °C.
	Malfunctioning control board or mechanical thermostat	If vaccine chamber temperature is below 2 °C while ambient temperature is above 10 °C, call for service.

Symptom	Possible Cause	Remedy
Low holdover or no holdover alarm	Power cord unplugged	Plug in power cord.
	Insufficient mains power unavailable	Check facility wiring or contact electricity supplier.
	Improper voltage supplied to refrigerator	Correct supply voltage and ensure the power outlet voltage matches the CFD-50's voltage input requirements.
	Not enough water in the water tank	Check water level and if needed, add water until level reaches bottom of the fill tube.
Compressor does not start (green light will turn on when compressor is running) when the display shows plug icon indicating power is available	Refrigerator is in its normal operating cycle	Compressor only runs occasionally to keep the ice lining fully frozen; every 6 hours to every 24 hours, depending on ambient temperature. If power is available for multiple days and holdover continues to decrease, refer to maintenance manual or call for service.
Compressor does not start when green compressor run light is on	Refrigeration system or control malfunction	Refer to maintenance manual or call for service.
Door won't close tightly	Latch is blocking the door	Make sure latch is not caught in the door, adjust tension of latch to hold door tightly closed.
	Refrigerator is not level	Level refrigerator by shimming underneath CFD-50.
	Gaskets are not installed properly	Make sure gaskets are pressed firmly into door and lie flat
	Damaged or leaking door gasket(s)	Replace damaged gasket(s).

Symptom	Possible Cause	Remedy
Vaccine chamber light does/does not illuminate when door is opened	Mains power unavailable	Chamber LED light will only illuminate when mains power is available
	Door has been open for more than 20 minutes	After a door excursion has occurred the door light will turn off. If more time is needed to load or unload vaccines, close and reopen the door to reset the alarm and light.
	Light is enabled/disabled	Light can be enabled or disabled by adjusting a jumper on the main electronics board. Refer to maintenance manual.
Condensation on the body of the refrigerator	High ambient humidity	Wipe down the condensation with a clean dry cloth.
Excess condensation water in the vaccine chamber	Clogged drain hole	Clean drain hole at the back of the vaccine chamber and tubing down to the drain pan, and empty drain pan.
	Prolonged door opening or door ajar	Avoid long door openings and ensure door is closed after use.
	Refrigerator is not positioned on a leveled and stable floor	Position the refrigerator on a stable floor and level it so that condensate flows to the drain in the back of the chamber
Heat on both sides for CFD-50 while compressor is running	CFD-50 has built-in condensers in its sides in addition to the external condenser.	Normal phenomenon, no action required.
Buzzing or dripping sound of liquid	Refrigerant flows within the CFD-50 or condensate flowing to drain pan.	Normal phenomenon, no action required.
Popping sound	Thermal contraction and expansion of the refrigeration system may cause occasional popping sound.	Normal phenomenon, no action required.
Clicking sounds	Occasional clicking sounds may be generated by relay or other electrical parts during compressor's starts and stops.	Normal phenomenon, no action required.

9 CFD-50 Specification

Model	CFD-50
Ambient Operating Temperature and Humidity Range	10 °C - 43 °C; Relative Humidity ≤ 95%
Vaccine Chamber Temperature Range	2 °C - 8 °C
Holdover Time @ +43 °C	120-hrs (5 days)
Vaccine Storage Capacity	50 L
Input Voltage Range	110 – 230 V
Input Frequency	50 – 60 Hz
Input Power	290 W (Peak)
Refrigerant	R134a/315g
External Dimensions	545 W * 655 D * 1588 H mm
Net Weight	102 kg

10 CFD-50 Disposal and Recycling Guidelines

- Remove the door and top lid when the CFD-50 is no longer in use.
- Disposal of the CFD-50 must be made according to local appliance disposal and recycling regulation.

Contact your local CFD-50 distributor and service provider for any questions not covered in this manual.

11 Warranty

To facilitate inquiries, please copy the model number and serial number in the following table.

Model		SN.	
-------	--	-----	--

To avoid losing the invoice, you can affix it to this page.

(Paste or staple your invoice here.)

Warranty Information

Thank you for using the MetaFridge CFD-50. Per the warranty card and invoiced date of sale (refer to the invoice), we will provide the following coverage to you.

- 1. Two-year warranty on the device, included at no extra cost.**
2. Under warranty coverage, the manufacturer will repair or replace device components that have failed in the use of the device for its designed intent.
Free warranty coverage does not include the following cases:
 - (1) Damage caused by improper use or improper maintenance.*
 - (2) Damage caused by attempted repairs done by a non-designated repair department.*
 - (3) Damage caused by force majeure.*
 - (4) Damage occurring after the warranty period has expired.*

Qingdao AUCMA Global Medical Co., Ltd

ADD: NO.315 Qianwangang Road, Economic & Technological
Development Qingdao, China

Zip: 266000

Tel: +86-532-88965799

Fax: +86-532-88965766

Email: info@aucma.com.cn

Website: www.aucmaglobal.com.cn